

RFbeam Microwave GmbH

RFbeam Microwave GmbH Farbgutstrasse 3 9008 St. Gallen Switzerland			Size A4	Revision C
Projekt:	ST100 Starterkit			
Objekt:	Overview			
Release Date :	29-Feb-2008	Print Date :	23-Jun-2008	Sheet: 1 of 5
File : Starterkit.sch				

(c) Copyright 2008 RFbeam Microwave GmbH
 This document contains intellectual property of RFbeam Microwave GmbH.
 It must not be distributed or published without written permission by RFbeam Microwave GmbH.

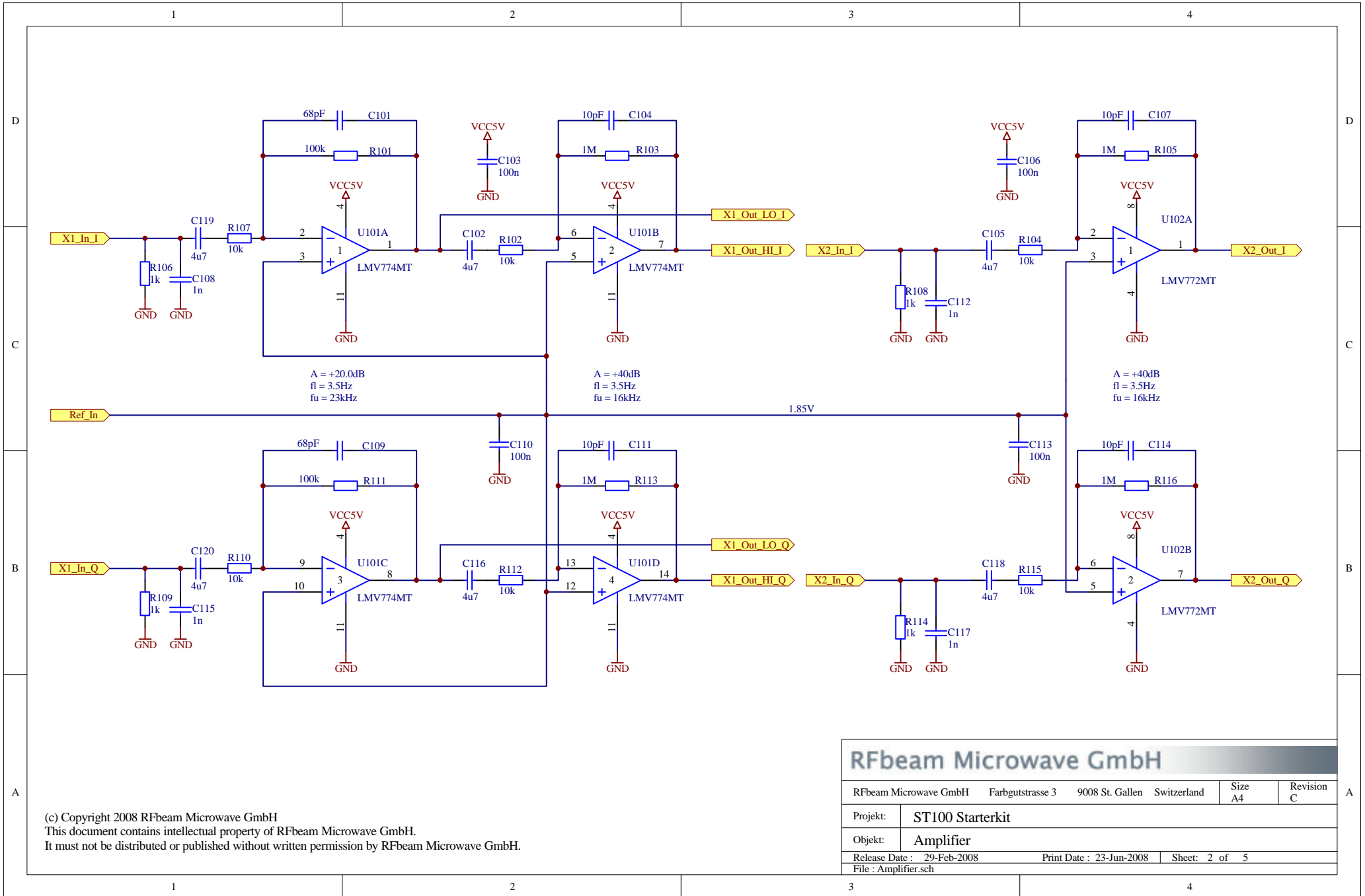

RFbeam Microwave GmbH

RFbeam Microwave GmbH Farbgutstrasse 3 9008 St. Gallen Switzerland			Size A4	Revision C
Projekt:	ST100 Starterkit			
Objekt:	Amplifier			
Release Date :	29-Feb-2008	Print Date :	23-Jun-2008	Sheet: 2 of 5
File : Amplifier.sch				

(c) Copyright 2008 RFbeam Microwave GmbH
 This document contains intellectual property of RFbeam Microwave GmbH.
 It must not be distributed or published without written permission by RFbeam Microwave GmbH.

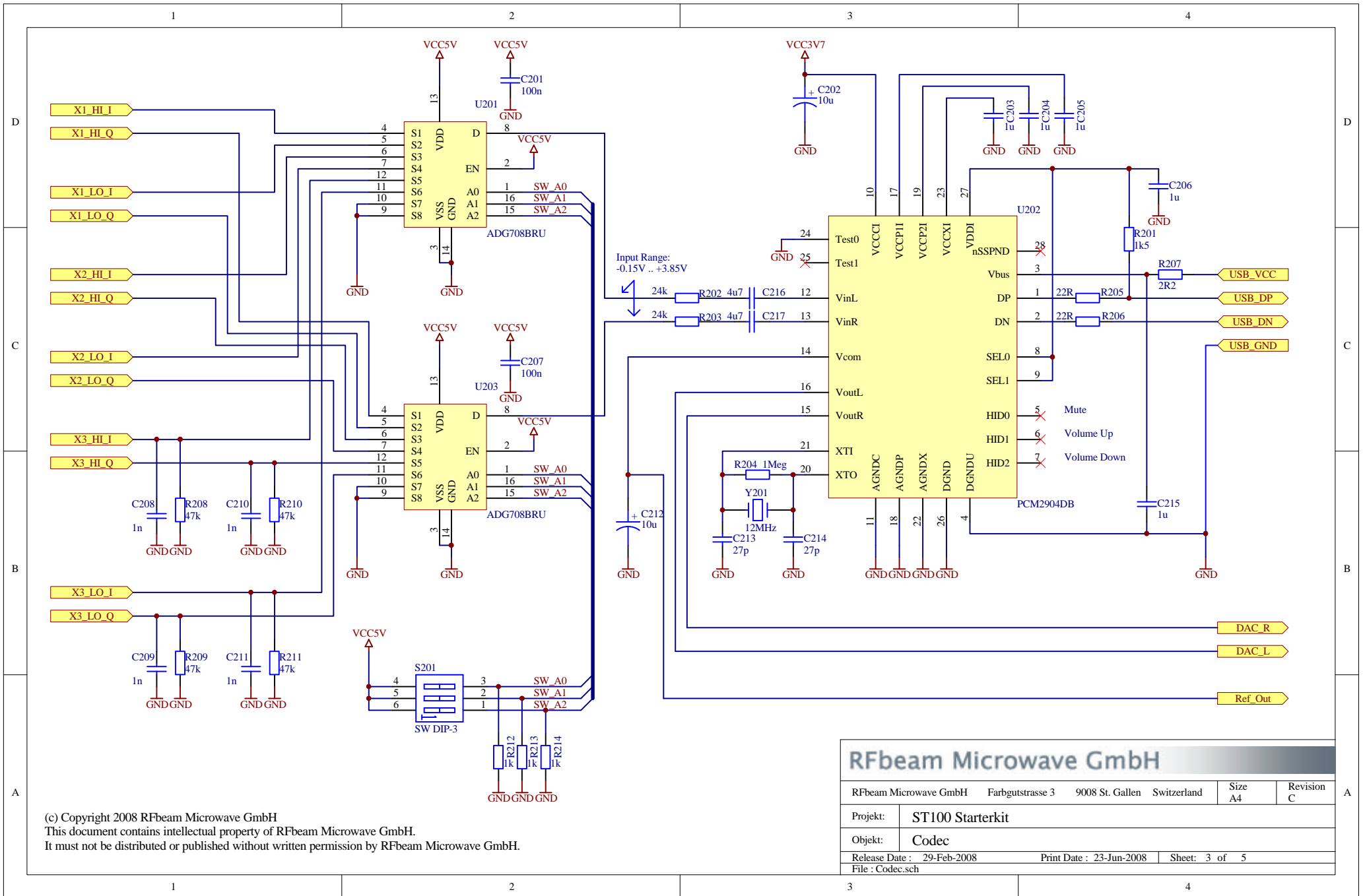

RFbeam Microwave GmbH

RFbeam Microwave GmbH		Farbgutstrasse 3		9008 St. Gallen		Switzerland		Size A4	Revision C
Projekt:	ST100 Starterkit								
Objekt:	Codec								
Release Date :	29-Feb-2008		Print Date :	23-Jun-2008		Sheet:	3 of 5		
File :	Codec.sch								

(c) Copyright 2008 RFbeam Microwave GmbH
 This document contains intellectual property of RFbeam Microwave GmbH.
 It must not be distributed or published without written permission by RFbeam Microwave GmbH.

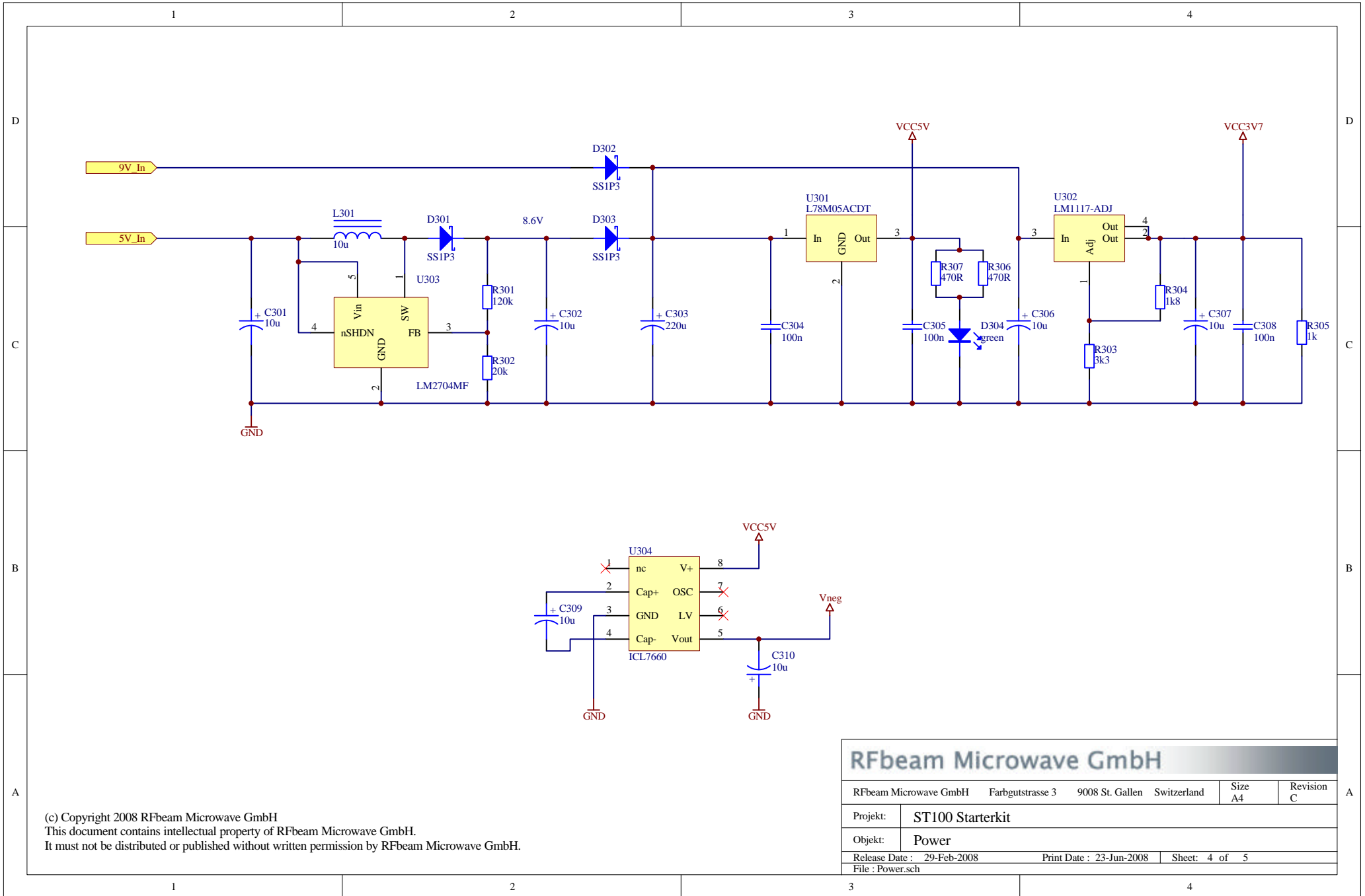

RFbeam Microwave GmbH

RFbeam Microwave GmbH Farbgutstrasse 3 9008 St. Gallen Switzerland			Size A4	Revision C
Projekt:	ST100 Starterkit			
Objekt:	Power			
Release Date :	29-Feb-2008	Print Date :	23-Jun-2008	Sheet: 4 of 5
File : Power.sch				

(c) Copyright 2008 RFbeam Microwave GmbH
 This document contains intellectual property of RFbeam Microwave GmbH.
 It must not be distributed or published without written permission by RFbeam Microwave GmbH.

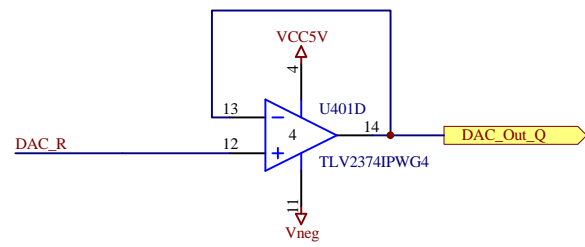
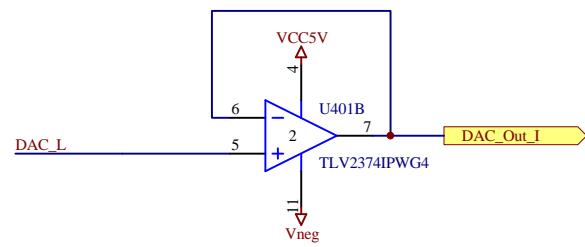
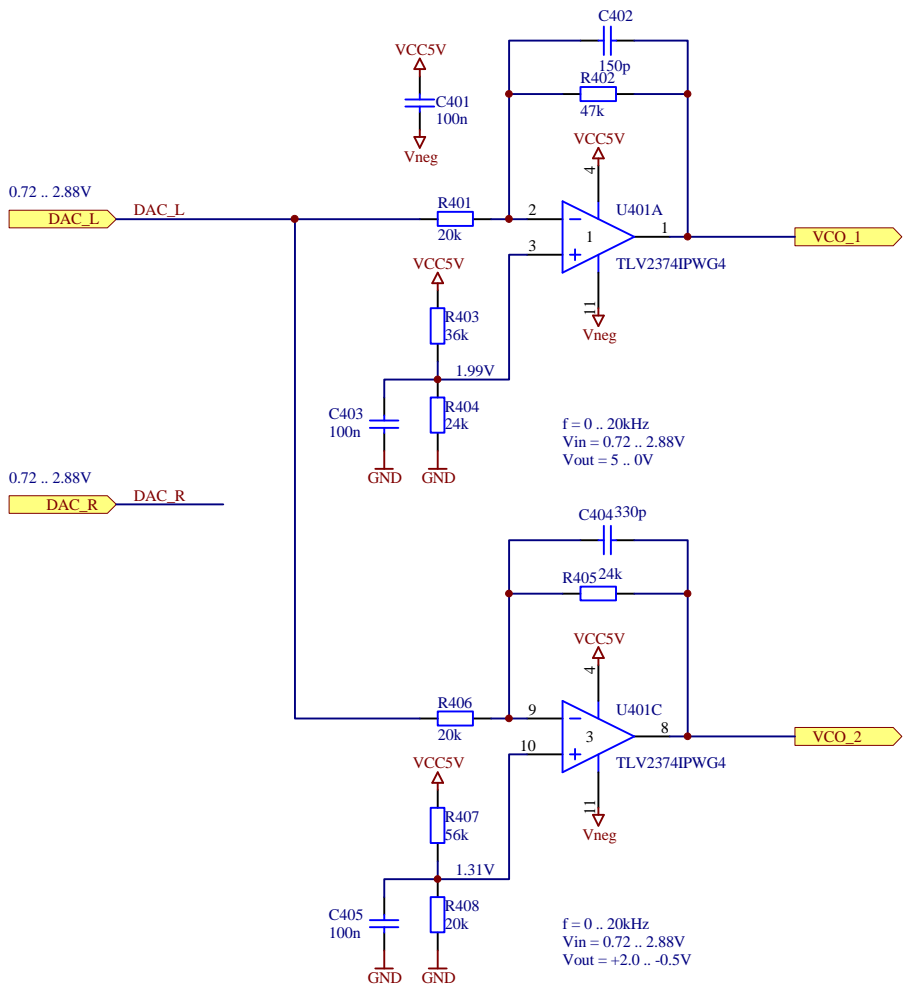

RFbeam Microwave GmbH

RFbeam Microwave GmbH			Farbgutstrasse 3	9008 St. Gallen	Switzerland	Size A4	Revision C
Projekt:	ST100 Starterkit						
Objekt:	Levelshifter						
Release Date :	29-Feb-2008	Print Date :	23-Jun-2008	Sheet:	5 of 5		
File : Levelshifter.sch							

(c) Copyright 2008 RFbeam Microwave GmbH
 This document contains intellectual property of RFbeam Microwave GmbH.
 It must not be distributed or published without written permission by RFbeam Microwave GmbH.